

DESCRIPTION AND APPLICATION GUIDELINES

# Roxtec casting guidelines

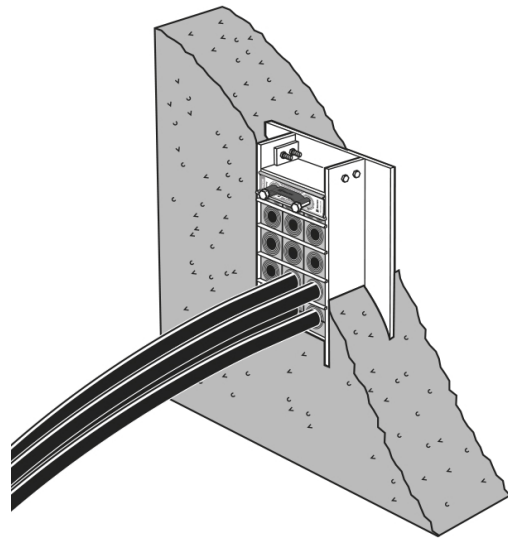
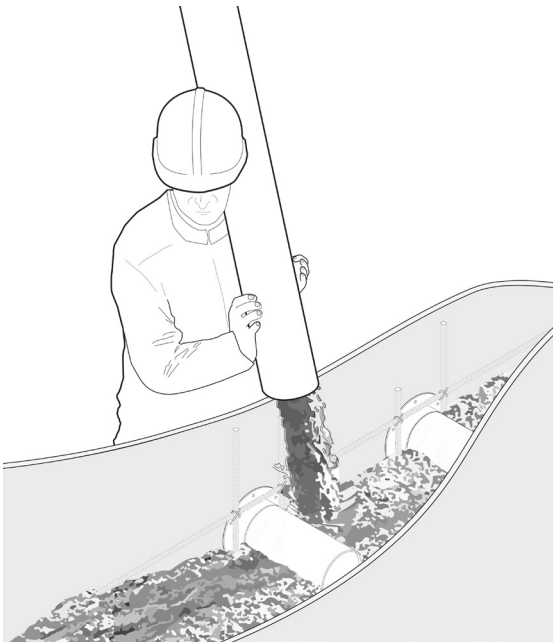

**Prepared for:** Roxtec International AB

**Date:** 2018-01-04

**Author:** Jens Bohlin, Roxtec Group,  
Box 540, Karlskrona, Sweden

## **Abstract**

These guidelines are a help for the construction workers casting Roxtec frames in concrete. The contents are not in detail covering aspects like concrete mix or how rebar structures are built as national codes apply on specific markets.

The rebar structure should be constructed in accordance with national codes and laws. If the rebar needs to be placed close to the frames and sleeves it is important to allow the concrete to fill any potential voids. This often requires space for a vibrator or other compaction equipment.

For product descriptions and auxiliary information, see [www.roxtec.com](http://www.roxtec.com)

# Contents

1. **Rectangular frames for casting**
  - 1.1 G frame
  - 1.2 GH frame
  - 1.3 GH FL100 frame
  - 1.4 B frame
  - 1.5 GH BG frame
  - 1.6 GH BG FL100 frame
2. **Round sleeves for casting**
  - 2.1 SLF sleeve
  - 2.2 SLFO sleeve
  - 2.3 SLF customization
3. **Accessories**
  - 3.1 EPS molds for frame
  - 3.2 GE extension frame
  - 3.3 Paper casting mold
  - 3.4 Termination lug for bonding and grounding
4. **Attachment – New-build**
  - 4.1 Attach the frame/sleeve to the rebar structure and shutters
  - 4.2 Attach the casting mold
5. **Attachment – Retrofit**
  - 5.1 Aperture
  - 5.2 Attach the frame/sleeve to the rebar structure and shutters
  - 5.3 Attach the casting mold
6. **Casting and consolidation**
  - 6.1 Casting and consolidation
  - 6.2 Finish
7. **Paper casting mold and core drilling**
8. **Special arrangements**
  - 8.1 Back-to-back arrangements
  - 8.2 Earth terminals
  - 8.3 EMC entries
  - 8.4 Inductive heating

# 1. Rectangular frames for casting

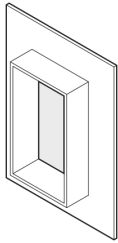

G frame

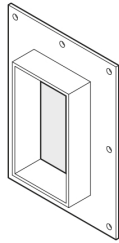

GH frame

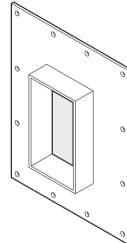

GH FL100 frame

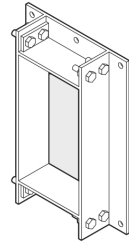

B frame

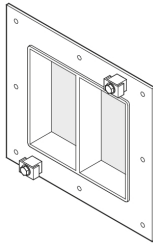

GH BG frame

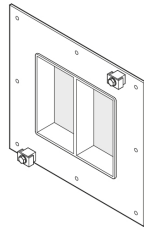

GH BG FL100 frame

## 1.1 G frame

The G frame has a 60 mm flange and is suitable in wall and floor applications in a new-build between shutters. It can also be used in retrofit where an openable frame is not needed. The frame can be attached to the rebar by welding or by drilling holes in the flange for binding wire.

## 1.2 GH frame

The GH frame is a G frame with 60 mm flange and with a number of pre-drilled holes in the flange. These can be used when attaching the frame to the rebar structure with binding wires.

## 1.3 GH FL100 frame

The GH FL100 frame is a GH frame with 100 mm flange and with a number of pre-drilled holes in the flange. These can be used when attaching the frame to the rebar structure with binding wires.

## 1.4 B frame

The B frame is primarily intended for applications where the casting is done around existing cables or pipes. The frame is also ideal when an expandable frame that can be designed and assembled on site is requested.

## 1.5 GH BG frame

The GH BG frame is a GH frame equipped with an earth terminal. It is primarily intended for applications where a welded earth terminal is required. The lug can house a threaded rod through the wall.

## 1.6 GH BG FL100 frame

The GH BG FL100 frame is a GH BG frame with 100 mm flange. It is primarily intended for applications where a welded earth terminal is required. The lug can house a threaded rod through the wall.

## 2. Round sleeves for casting

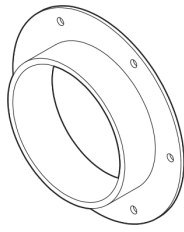

SLF sleeve

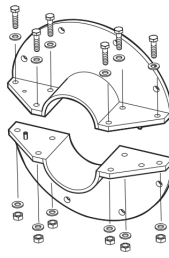

SLFO sleeve

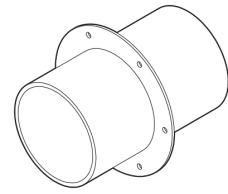

SLF customization

### 2.1 SLF sleeve

The SLF sleeve is suitable for wall and floor applications in a new-build between shutters. It can also be used in retrofit where an openable sleeve is not needed. The sleeve can be attached to the rebar by welding or by using binding wire.

### 2.2 SLFO sleeve

The SLFO is an openable sleeve, primarily intended in applications where the casting is done around existing cables or pipes. The sleeve can be attached to the rebar structure by welding or by using binding wires.

### 2.3 SLF customization

The SLF sleeve can be ordered in any depth to fit the structure. The flange is centered in depth.

### 3. Accessories

The accessories are used together with regular frames, or with round frames/seals, when casting them into concrete structures. These are not a part of the sealing system, rather an installation aid.

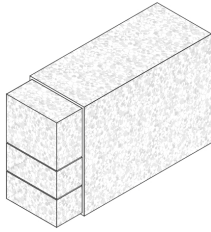

EPS mold for frame

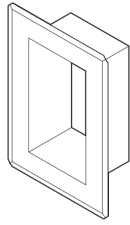

GE extension frame

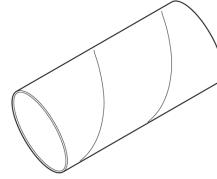

Paper casting mold

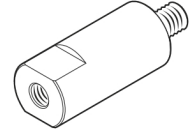

Termination lug

#### 3.1 EPS molds for frame

The casting mold gives the correct dimension of the passage through the wall which assures that the stayplates and compression unit can work properly in the installation. For use in structures with thickness up to 360 mm. The mold is cut on site to the correct depth and is squeezed between the shutters.

#### 3.2 GE extension frame

The GE extension frame may be used after casting as an extension when the regular frame is not deep enough to protrude through the wall structure and to cover rough edges in the concrete. Its purpose is mainly aesthetical.

#### 3.3 Paper casting mold

This mold creates a defined hole for round frames or seals. After removal of the mold, there is no need for a sleeve. The mold can be used in structures up to 1100 mm and is cut on site to the correct depth and is squeezed between the shutters.

#### 3.4 Termination lug for bonding and grounding

The BG rod is used to bond the metallic frame/sleeve to earth for equipotential bonding. The rod is attached to the flange and protrudes flush with the frame/sleeve.

## 4. Attachment - New-build

### 4.1 Attach the frame/sleeve to the rebar structure and shutters

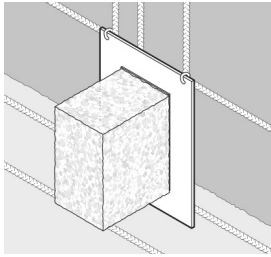

G frame attached to rebar fitted with mold

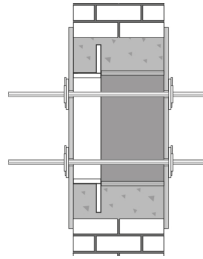

Frame/sleeve cast in wall

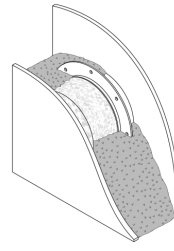

SLF sleeve cast in wall

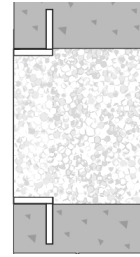

G frame in concrete wall

Attach the frame/sleeve to the rebar structure by welding or by using binding wires. The frame/sleeve can be placed on either side of the wall or floor, unless otherwise stated in the project specification. Make sure to have the flange turned within the wall. Seals designed to be used underground can either have the frame/sleeve on the inside for an accessible seal after the trench is filled or on the outside to prevent standing water in the foundation.

### 4.2 Attach the casting mold

Put the casting mold in the frame and cut it to the appropriate length. Both sides of the mold are squeezed between the shutters to prevent intrusion of casting fluids. The EPS mold creates a channel through the wall and a void around the inside of the frame. This void allows the stayplates to move during compression of the system and is essential for the functionality. The channel through the wall using standard sleeves can be done on site using appropriate material. An option is to use longer sleeves with the same depth as the structure.

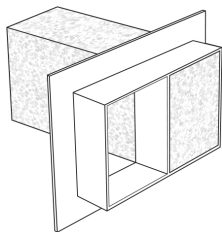

G frame with EPS mold

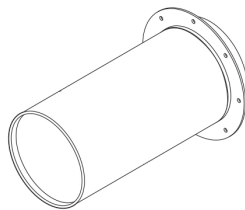

SLF sleeve with plastic pipe

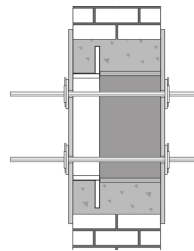

G frame cast in wall

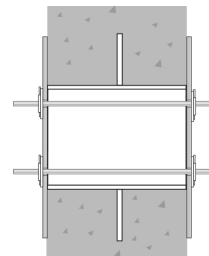

SLF sleeve cast in wall

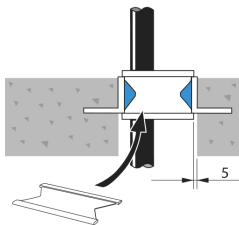

The void must allow the stayplate to move

## 5. Attachment - Retrofit

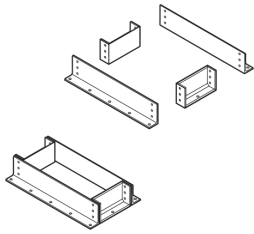

B frame for retrofit solutions

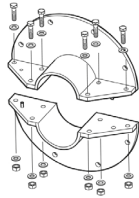

SLF sleeve for retrofit solutions

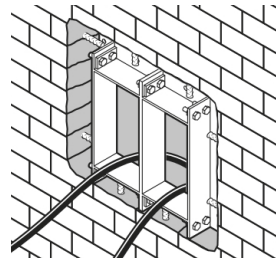

B frame attached to rebar

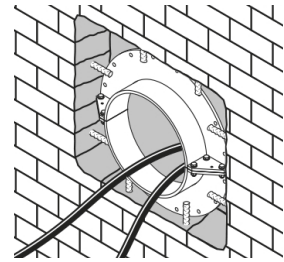

SLF frame attached to rebar

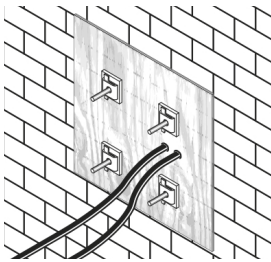

Frame/sleeve covered with shutters

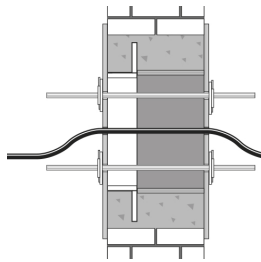

Frame/sleeve cast in wall

### 5.1 Aperture

Make sure that the aperture in the wall/floor for the frame/sleeve is large enough to accommodate rebar and shutters for the casting.

### 5.2 Attach the frame/sleeve to the rebar structure and shutters

In retrofit solutions the frame/sleeve is first built around existing cables and pipes. Attach the frame/sleeve to the rebar structure by welding or by using wires. The frame/sleeve can be placed on either side of the wall or floor, unless otherwise stated in the project specification. Make sure to have the flange turned within the wall.

### 5.3 Attach the casting mold

Build a casting mold in appropriate size. Put the casting mold over the frame and cut it to the appropriate size. Both ends of the mold are squeezed between the shutters so it is important to make a careful cut. The mold must create a channel through the wall and a void around the inside of the frame. This void allows the stayplates to move during compression of the system and is essential for the functionality. The mold is to be adapted to the existing cables or pipes prior to attaching it to the frame or sleeve.

The channel through the wall using standard sleeves and frames can be done on site using plywood or other appropriate sheets. An option is to use longer sleeves with the same depth as the structure.



## 6. Casting and consolidation

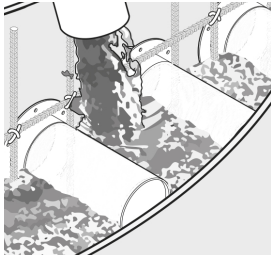

Pouring concrete into mold

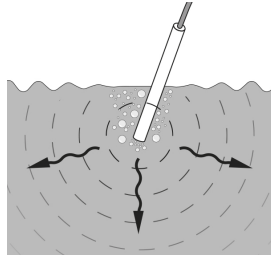

Vibrate concrete



Vibrate concrete

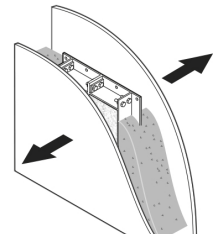

Remove the shutters

### 6.1 Casting and consolidation

Avoid pouring large masses of concrete directly onto the frames/sleeves and molds. The w/c ratio must be well balanced to allow the concrete to fill any voids around the frame/sleeve but still remain watertight. A suitable grade of aggregate that is well consolidated also contributes to obtain watertight penetration. If there is a lot of force on the casting mold during the casting process it might be necessary to support it to avoid geometrical deformation.

### 6.2 Finish

Remove the shutters and casting mold and clean any concrete spill from within the frame/sleeve. Complete the installation with sealing modules.

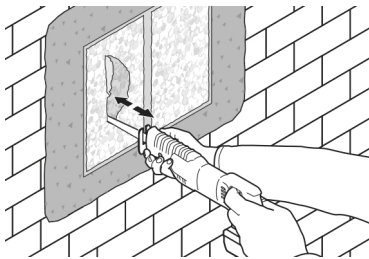

Remove mold

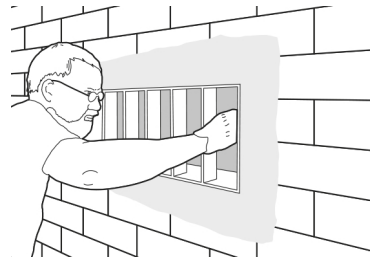

Clean the apertures from spill

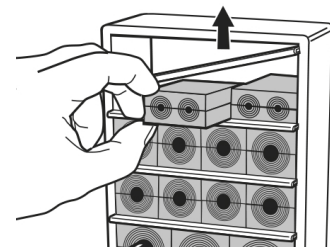

Installation of sealing modules

## 7. Paper casting mold and core drilling

The paper casting mold makes the same type of aperture as core drilling. The benefit is to have the hole in place already after the casting. The mold should be supported at the ends using a lid or other reinforcements to prevent non-circular aperture for the sealing.

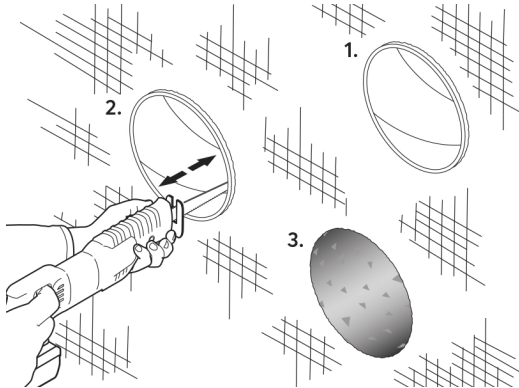

Paper cast aperture

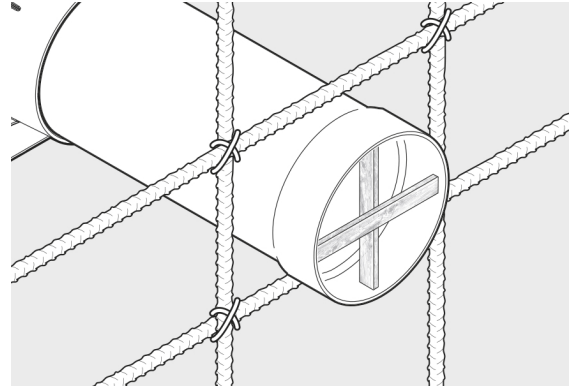

Reinforced opening

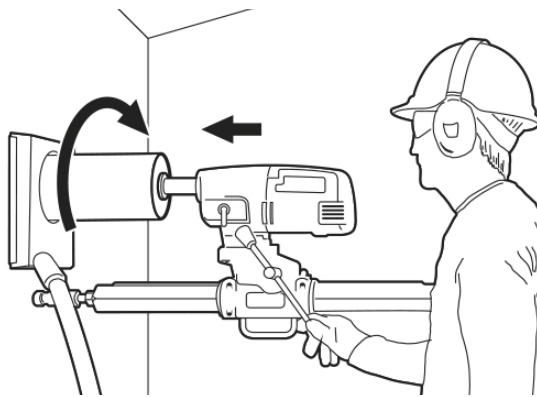

Core drilled aperture

## 8. Special arrangements

### 8.1 Back-to-back arrangements

Two frames can be cast in, one from each side, to create a double barrier for increased fire protection.

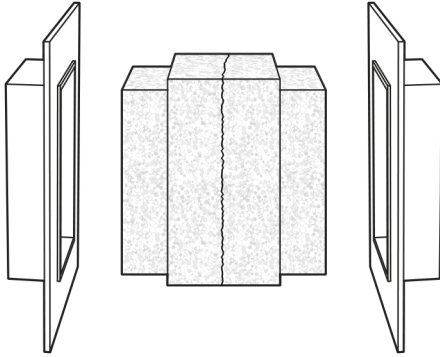

G frames with EPS mold

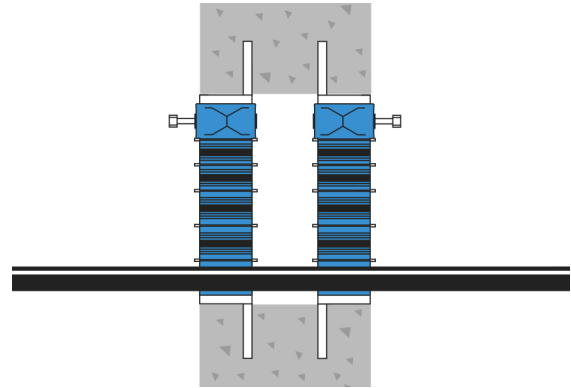

G frames cast back-to-back

### 8.2 Earth terminals

Earth terminals should be attached to the frame before casting to create a ground path from the frame through the wall or floor.

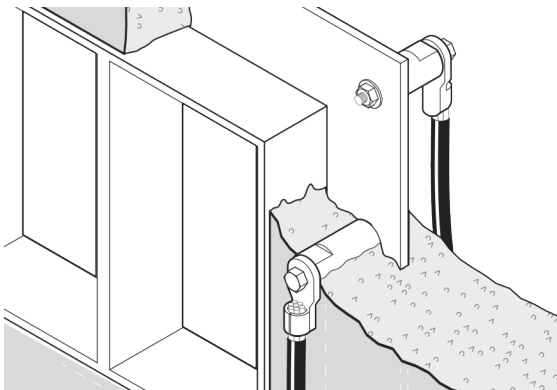

Termination lugs on both sides of the frame

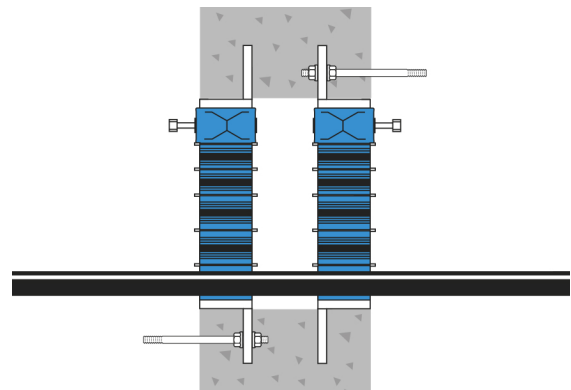

Alternate method of grounding frame.  
Earth terminals protruding through the shutters

Frames with pre-welded earth terminals are available as BG versions of frames. When GH frames are to be installed, unused holes can be used to attach earthing accessories such as terminals and rods. The dimensions on the termination lugs must be according to national codes and regulations.

### 8.3 EMC entries

When building a shielded zone, the rebar structure can be used as a part of the shielding system. The mesh must have a spacing corresponding to the specified cut-off frequency and be connected to the frame at all ends. High frequency demands require smaller mesh size.

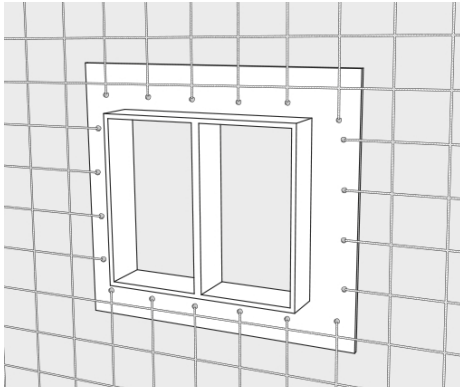

G frame attached to rebar in shielded applications

### 8.4 Inductive heating

It is recommended to use stainless steel material whenever single core cables are used to avoid inductive heating. For the same reason, the rebar system should not interfere between single core cables. Try to achieve trefoil symmetry.

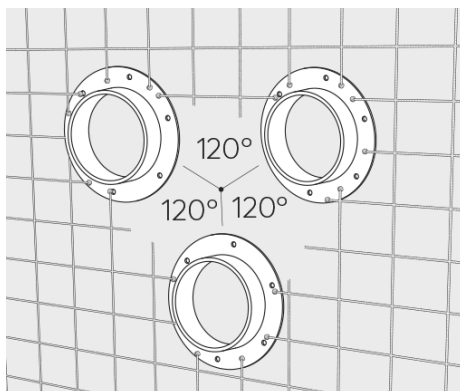

Sleeves in trefoil application

## DISCLAIMER

"The Roxtec cable entry sealing system ("the Roxtec system") is a modularbased system of sealing products consisting of different components. Each and every one of the components is necessary for the best performance of the Roxtec system. The Roxtec system has been certified to resist a number of different hazards. Any such certification, and the ability of the Roxtec system to resist such hazards, is dependent on all components that are installed as a part of the Roxtec system. Thus, the certification is not valid and does not apply unless all components installed as part of the Roxtec system are manufactured by or under license from Roxtec ("authorized manufacturer"). Roxtec gives no performance guarantee with respect to the Roxtec system, unless (I) all components installed as part of the Roxtec system are manufactured by an authorized manufacturer and (II) the purchaser is in compliance with (a), and (b), below.

(a) During storage, the Roxtec system or part thereof, shall be kept indoors in its original packaging at room temperature.

(b) Installation shall be carried out in accordance with Roxtec installation instructions in effect from time to time.

The product information provided by Roxtec does not release the purchaser of the Roxtec system, or part thereof, from the obligation to independently determine the suitability of the products for the intended process, installation and/or use. Roxtec gives no guarantee for the Roxtec system or any part thereof and assumes no liability for any loss or damage whatsoever, whether direct, indirect, consequential, loss of profit or otherwise, occurred or caused by the Roxtec systems or installations containing components not manufactured by an authorized manufacturer and/or occurred or caused by the use of the Roxtec system in a manner or for an application other than for which the Roxtec system was designed or intended.

Roxtec expressly excludes any implied warranties of merchantability and fitness for a particular purpose and all other express or implied representations and warranties provided by statute or common law. User determines suitability of the Roxtec system for intended use and assumes all risk and liability in connection therewith. In no event shall Roxtec be liable for indirect, consequential, punitive, special, exemplary or incidental damages or losses."

